

Xrefs: Potth: S:\ENGINEERING\Traffic\FOLDERS\Cinet\Draft Revised Standards_Master.dwg Plot Date: Jan 04, 2021 at 14:25

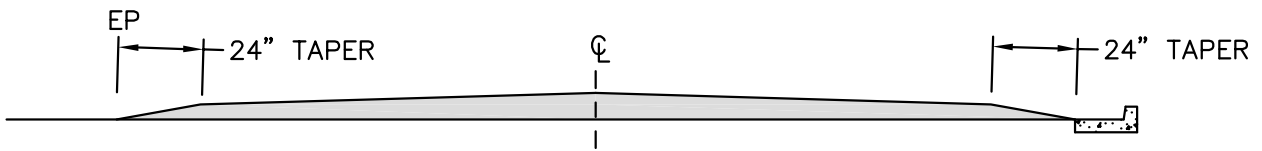

SECTION A-A

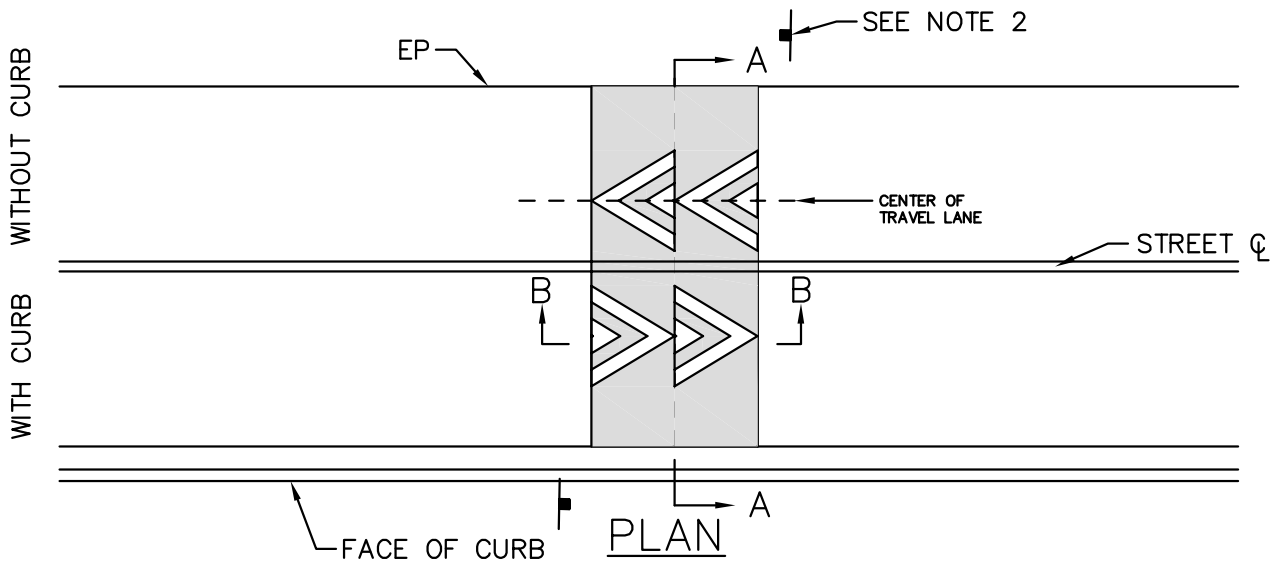
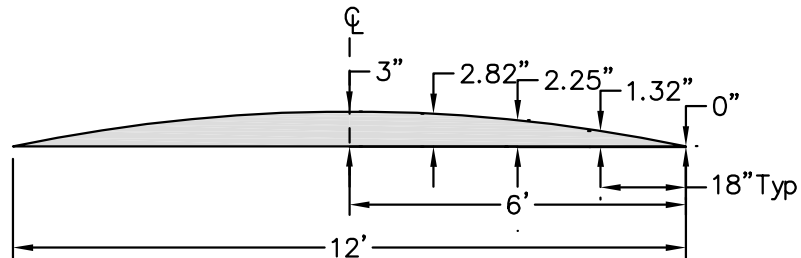

SECTION B-B

NOTES:

1. SPEED HUMPS MAY BE INSTALLED ONLY IF APPROVED BY THE DIRECTOR OF THE DEPARTMENT OF TRANSPORTATION AND PUBLIC WORKS.
2. SPEED HUMP SIGNAGE AND MARKINGS SHALL BE INSTALLED PER CA MUTCD AND MEET CALTRANS SPECIFICATIONS. ADDITIONAL ADVANCE SIGNAGE AND MARKINGS MAY BE REQUIRED BY DTPW.

COUNTY OF SONOMA DEPARTMENT OF TRANSPORTATION AND PUBLIC WORKS		
<h2 style="margin: 0;">TYPICAL SPEED HUMP</h2>		
DATE: DEC, 2020	REVISED:	
APPROVED BY:	SCALE: NONE	DRAWING NO. 850